

Benefits of Belonging

APS MEMBER BENEFITS BROCHURE | 2017/18

EXPRESSION OF INTEREST IN ADVERTISING

The Member Benefits brochure is distributed annually to 22,400 APS members.

The brochure is circulated at a wide range of events and conferences that we hold or partner-in and published on our website, giving it an audience of at least 50,000 people.

The brochure details the full range of benefits, resources and support services that the APS offers its members. Inclusion in our member benefits regime offers unique and exclusive access to our members and their networks. Only organisations offering a particular benefit or service to our members are typically included in our Member Benefits brochure.

APS members are professional, well-educated and have nation-wide reach.

► To be part of the Member Benefits brochure 2017/18 please complete the Expression of Interest form on page 3.

Booking deadline: 3 March 2017

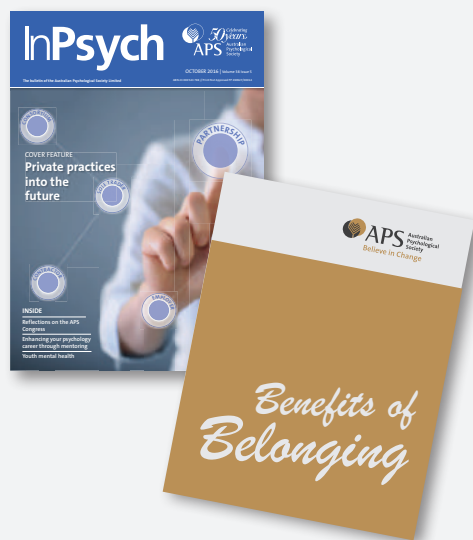

Circulation: 22,400+ members, annually

Booklet size: 210mm w x 275mm h

FULL PAGE AD 210mm w x 275mm h
(Includes: Back cover, inside front cover and inside back cover options)

HALF PAGE AD Horizontal 190mm w x 120mm h

QUARTER PAGE AD 90mm w x 120mm h

To discuss this opportunity in more detail, please contact:

psychology.org.au/advertising

e: apsadvertising@psychology.org.au

t: +61 3 8662 3300 | f: +61 3 9663 6177

Rates

Full colour or mono	Standard rate (\$) incl. GST
Full page 210mm W x 275mm H	\$3000
Half page 190mm W x 120mm H	\$1800
Quarter page 90mm W x 120mm H	\$1200
Full page – SPECIAL POSITION	
• Back cover	\$3700
• Inside front cover	\$3590
• Inside back cover	\$3445

Artwork specifications

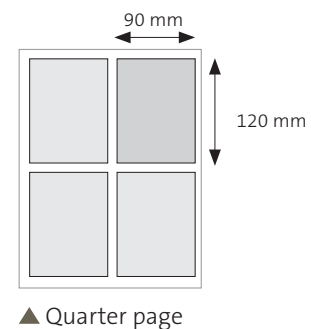
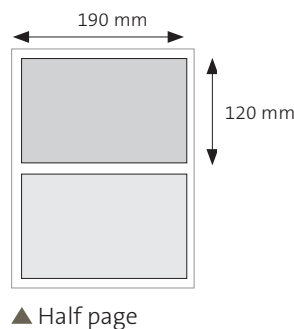
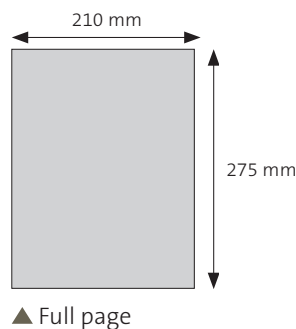

Artwork format

Formats for advertising artwork (in this order of preference):

1. **High resolution CMYK PDF**
300 dpi / press ready with crops and 3mm bleed
PDF artwork to be supplied via email (maximum 5MB file size) to:
apsadvertising@psychology.org.au
2. InDesign – including all graphic and font files
3. Illustrator EPS – fonts outlined and 300 dpi images embedded
4. High res TIF or JPEG – CMYK

IMPORTANT NOTE: On Full page advertising please make sure that all text remains within an 8mm margin from the edge.

Please note: The APS reserves the right to correct spelling errors, redesign ads, request different imagery due to layout or content concerns, or decline requests depending on demand.

Terms and Conditions:

- There is a limit to the number of advertisements per program. A maximum of 3 pages of ad space in total – to be made up of full, half and/or quarter page ads. Only one advertisement is allowed per advertiser.
- Advertisers must include an exclusive benefit to APS Members which is to be available for the period of the program 2017/2018.
- Payment will only be processed once the booking has been confirmed.
- The APS reserves the right to cancel or reject advertising deemed not to be in keeping with its scientific and professional aims.
- All advertisement and insert final artwork must be approved by the APS before publishing.
- All advertising in APS publications and at APS events must comply with the APS Code of Ethics and any relevant requirements stipulated by the Psychology Board of Australia or the Australian Health Practitioner Regulation Agency, regardless of whether or not the external advertiser/sponsor is a registered psychologist, or is providing a regulated health service or an education and training program. For details, refer to the

Advertising Deadline

Member Benefits brochure 2017/18 will be inserted in the April edition of *InPsych* magazine, the APS's flagship publication sent to all members. The April issue is scheduled for distribution by the middle of the month.

- ▶ **Advertisement booking deadline:**
3 March 2017 COB
(ad space is strictly limited)
- ▶ **Advertisement artwork & payment deadline:**
10 March 2017 COB

APS Ad Creation Service

PREMIUM SERVICE: \$300 (incl. GST)

The APS provides an advertising artwork service for full, half, and quarter page ads in full colour.

Includes: artwork for one ad layout option and one round of author's corrections.

The advertiser must supply the following:

- PDF example of a previous ad style to base the new ad artwork
- Logos provided in vector file format
- Photos to be provided in hi-resolution (300dpi).
- Final copy/text to be included

- ▶ **Deadline for supplying artwork for ad creation:**
6 March 2017 COB

'Information for advertisers' document, which can be downloaded at psychology.org.au/publications/inpsych

- The APS makes every reasonable effort to publish *InPsych* according to the distribution schedule. The APS is not liable for any loss or damage incurred by an advertiser as a result of any failure or delay in the distribution of *InPsych* and associated insert advertising.
- Advertising deadlines are included on this form. Advertisers are required to pay in full by the payment deadline.
- If payment has not been received for an advertisement by the deadline date, that advertisement will not be published and the cancellation fee will apply.
- Cancellation of an advertisement or insert after the booking deadline will incur a cancellation fee of 50% of the advertising fee for that advertisement.
- Payment can be made by credit card (Visa, MasterCard, and American Express) or cheque.

ALL ADVERTISING IS SUBJECT TO APPROVAL and must comply with APS Code of Ethics and Psychology Board of Australia advertising guidelines. Your advertisement must offer a suitable benefit/discount offer for APS members to be accepted. Expressions of Interest are not confirmation of booking.

APS MEMBER BENEFITS BROCHURE | 2017/18
EXPRESSION OF INTEREST IN ADVERTISING



Please scan and email, fax or post this completed agreement to:

Advertising

The Australian Psychological Society Limited
PO Box 38, Flinders Lane, VIC 8009
Phone: +61 3 8662 3326
1800 333 497 (toll free within Australia)
Fax +61 3 9663 6177
Email: apsadvertising@psychology.org.au

APS Member Benefits Program

TAX INVOICE ABN 23 000 543 788

I wish to express my interest in advertising in the APS Member Benefits brochure for 2017/18.

I have read and understand the Terms and Conditions. (please tick)

ADVERTISER DETAILS:

Advertiser: _____ Contact name: _____

Media/advertising agency (if applicable): _____

BILLING DETAILS (Person/company responsible for payment)

Client/company/APS Unit: _____

Media/advertising agency (if applicable): _____

First name: _____ Surname: _____

Billing address: _____ State: _____ Postcode: _____

Phone: _____ Fax: _____

Email: _____ Separate tax invoice required? (see Terms and Conditions): Yes No

BOOKING DETAILS

Advertisement size:

- Full page
Preference: Back cover Inside front cover Inside back cover No preference
 Half page
 Quarter page

Ad creation service:*

- BASIC service PREMIUM service
 Yes (I will supply all ad content by relevant booking deadline)

*Additional fees, terms of conditions apply. Refer to page 2 for information.

Please summarise your offer to APS members (i.e. Receive 10% off your next shop)

PAYMENT DETAILS

I enclose a cheque for (\$AUD): _____ PLEASE MAKE CHEQUES PAYABLE TO THE AUSTRALIAN PSYCHOLOGICAL SOCIETY LIMITED

OR I authorise the APS to charge my (please tick): American Express MasterCard Visa **TOTAL (\$AUD):** _____

Card number: _____ Expiry date: _____

Cardholder's name: _____ Authorised debit amount (\$AUD): _____

Signature: _____ Date: _____

OFFICE USE ONLY	
ENT.	_____
INV.	_____